

PCE Americas Inc.
711 Commerce Way
Suite 8
Jupiter
FL-33458
USA
From outside US: +1
Tel: (561) 320-9162
Fax: (561) 320-9176
info@pce-americas.com

PCE Instruments UK Ltd.
Units 12/13
Southpoint Business Park
Ensign way
Hampshire / Southampton
United Kingdom, SO31 4RF
From outside UK: +44
Tel: (0) 2380 98703 0
Fax: (0) 2380 98703 9
info@pce-instruments.com

www.pce-instruments.com/english
www.pce-instruments.com

Manual Scales PCE-EP Series

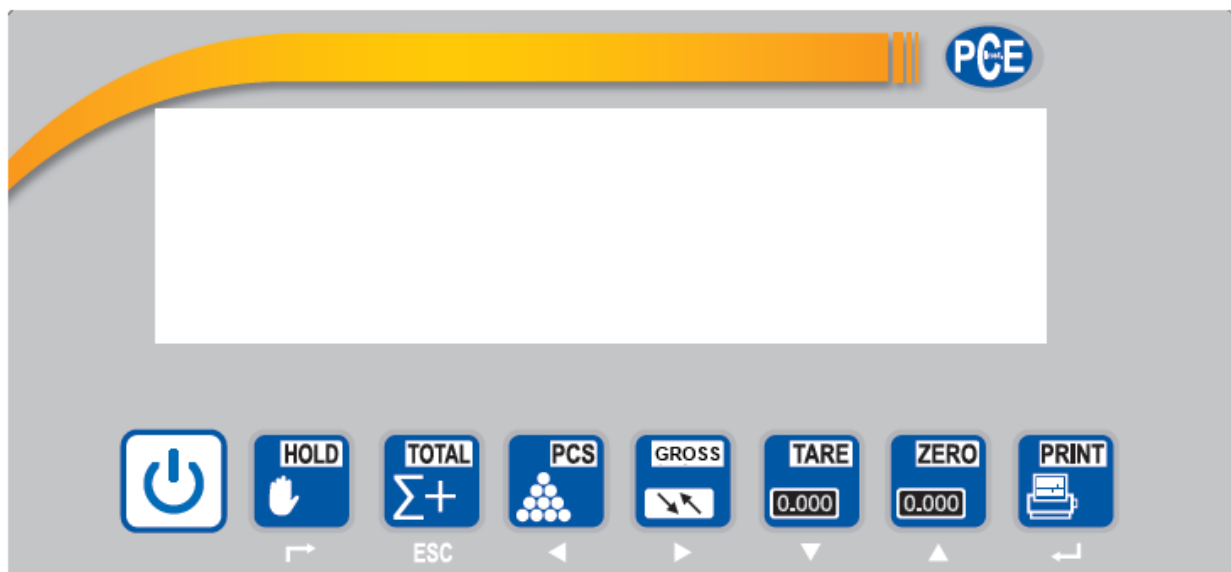

Contents

1	Introduction	3
2	Safety notes	3
3	Specification	4
4	System description	5
4.1	Display	5
4.2	User interface	5
4.3	Interfaces	7
4.3.1	Power supply unit.....	7
4.3.2	Cell connection	7
4.3.3	RS-232 interface	8
4.3.4	Sending format.....	10
4.4	Operation	13
4.4.1	Turn ON/OFF.....	13
4.4.2	Zeroing	13
4.4.3	Taring "TARE"	13
4.4.4	GROSS / NET.....	14
4.4.5	Summing "TOTAL"	15
4.4.6	Piece counting function "COUNT".....	16
4.5	Menu	16
5	Maintenance and Cleaning	28
5.1	Battery information.....	28
5.2	Mains operation	28
5.2.1	Cleaning	28
6	Disposal	29
7	Contact	30
7.1	PCE Instruments UK.....	30
7.2	PCE Americas	30

1 Introduction

Thank you for purchasing pallet scales from PCE Instruments.

Pallet Scales PCE-PE Series are designed for the quick and comfortable weighing of pallets. To do that, the euro-pallet is put in between of the bars with the help of a pallet truck. Without the need to drive out the pallet truck, the weight can be determined and the pallet can be taken away with the pallet truck again. The scales provide an internal battery and can be transported easily thanks to the installed wheels. Functions of the scales are piece counting, totalising, and brutto-netto weighing as well as limit weighing. Moreover, the scales possess a bidirectional RS-232 interface.

2 Safety notes

Please read this manual carefully and completely before you use the device for the first time. The device may only be used by qualified personnel and repaired by PCE Instruments personnel. There is no warranty of damages or injuries caused by non-observance of the manual.

- This instrument may only be used the way, described in this manual. If the instrument is applied differently, there might be danger for the operator and destruction of the instrument may occur.
- The instrument may not be exposed to extreme temperature, direct sunlight, extreme humidity or moisture.
- Do not operate the instruments with wet hands.
- The instrument may not be cleaned with solvents or abrasives.
- You must not make technical changes on the device.
- Check the housing before using the instrument. If there are any visual damages, do not operate the instrument
- If the battery is flat (displayed by the battery indicator), the instrument may not be used anymore, because danger to the operator might occur.
- Measure known quantities before the application of this device.
- The instrument may only be applied with accessories from PCE Instruments or equivalent accessories.
- Under no circumstances, any of the specified limits for the measurement units may be exceeded.
- Moreover, this microscope may not be used in explosive atmosphere.
- If you do not refer to the safety notes, the instrument may be damaged and personal injury may occur.
- Make sure to use a suitable surface, which does not transfer vibrations or is placed next to heavy machines.
- Avoid unstable power supply.

This user's handbook is published from PCE Instruments without any guarantee.

We expressly point to our general guarantee terms, they can be found in our general terms of business.

If you have any questions please contact PCE Instruments.

3 Specification

Of the display

Display	6 digit
Resolution	
Display	30.000
ADC	2.000.000
Temperature influence on the zero signal	TK0 < 0.1 $\mu\text{V}/\text{K}$
Influence on power supply	TKspn < ± 6 ppm//K
Sensitivity (internal)	0,3 $\mu\text{V} / \text{d}$
Measurement voltage	-30 ... +30 mV DC
Supply voltage	5 VDC
Load cell connection	Max. 6 cells 4 or 6 conductor 350 Ω
Supply voltage	AC 100 ... 250 V
Temperature range	-10 ... +40 $^{\circ}\text{C}$

Of the scales

Weighing range	0 ... 1.500 kg
Readability	0,5 kg
Repeatability	± 2 kg
Tare range	100 % / Multiple tare
Display	LCD
Power supply	Power adapter 9 V / 1,2 AA or 6V / 4 Ah lead accumulator

Material

Weighing platform	Painted steel
Display	Stainless-steel
Protection class	IP 54
Working temperature	0 ... +40 $^{\circ}\text{C}$ / 10 ... 80 % r.h.
Dimensions U-form	1200 x 840 x 750 mm
Weight	70 kg





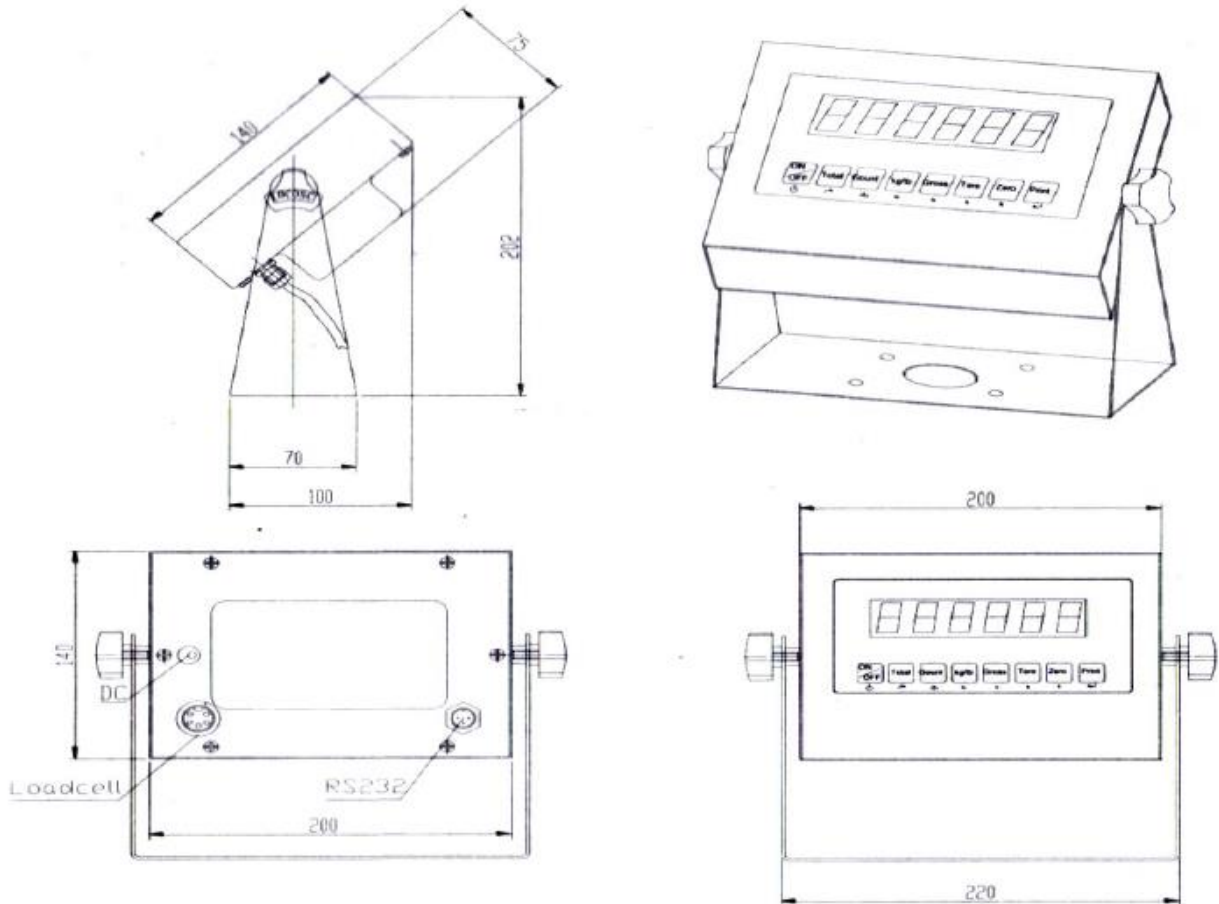

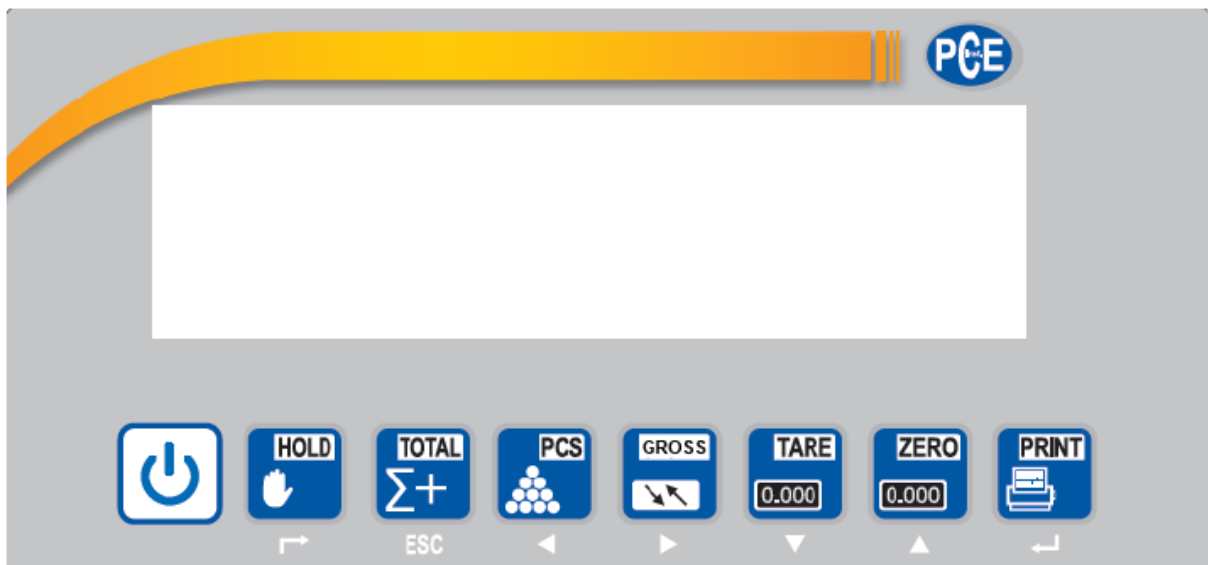

4 System description

4.1 Display



4.2 User interface

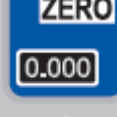

	<p>“ON / OFF” Pressing this button, you can switch the power of the scales on. Pressing the button for a longer time will turn the scales OFF.</p>
	<p>„HOLD“ This button freezes the reading. Pressing this button again you will return to the normal weighing mode.</p> <p>The function serves to hold the reading in the display, even if the weighing product is removed from the scales.</p>
 <p>ESC</p>	<p>„TOTAL“ With this button, you can sum up the weight (+). Moreover, it allows you to display the total weight.</p> <p>In the menu screen, the button is used to exit a function (ESC)</p>
 <p>←</p>	<p>“PCS“ (piece counting) With this button, you can perform piece counting of heavyweight articles with the help of weight determination.</p> <p>In the menu screen, the button is used to achieve the left side.</p>
 <p>▶</p>	<p>„GW / NW“ With this button, you can view the “GROSS / NET” weight. This weight is the weight in consideration of the tare weight.</p> <p>In the menu screen, the button is used to achieve the right side.</p>
 <p>▼</p>	<p>„TARE“ With this button, you can tare the displayed weight.</p> <p>In the menu screen, the button is used to lower a value.</p>
 <p>▲</p>	<p>„ZERO“ With this Button, you can reset the displayed weight. This is not considered in “GROSS / NET” process (in contrast to the TARE function).</p> <p>In the menu screen, the button is used to increase a value.</p>
 <p>↵</p>	<p>„PRINT“ With this button, your data can be transferred to a printer or computer via RS-232 interface.</p> <p>In the menu screen, the button is used to confirm your selections (“ENTER”).</p>

4.3 Interfaces

4.3.1 Power supply unit

9 V / 1,2 A / external (-) / internal (+)

4.3.2 Cell connection

The display can be connected with up to 6 cells (4 or 6 conducted) with maximum a resistance of 350Ω.

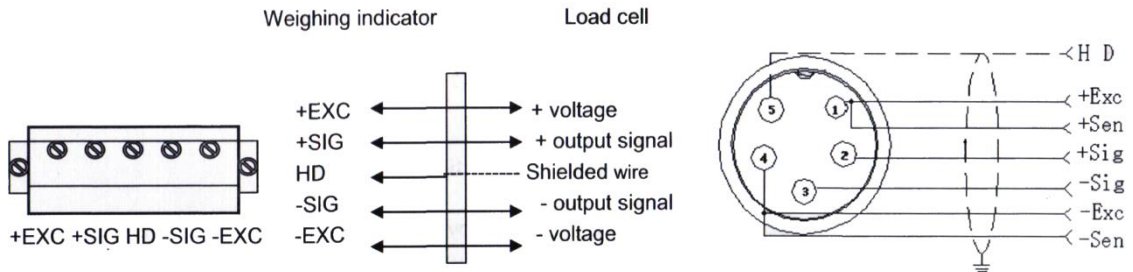

+Exc = red cable

+Sig = green cable

Shie = black cable (shrinking tube with small marking)

Sig = white cable

-Exc = black cable

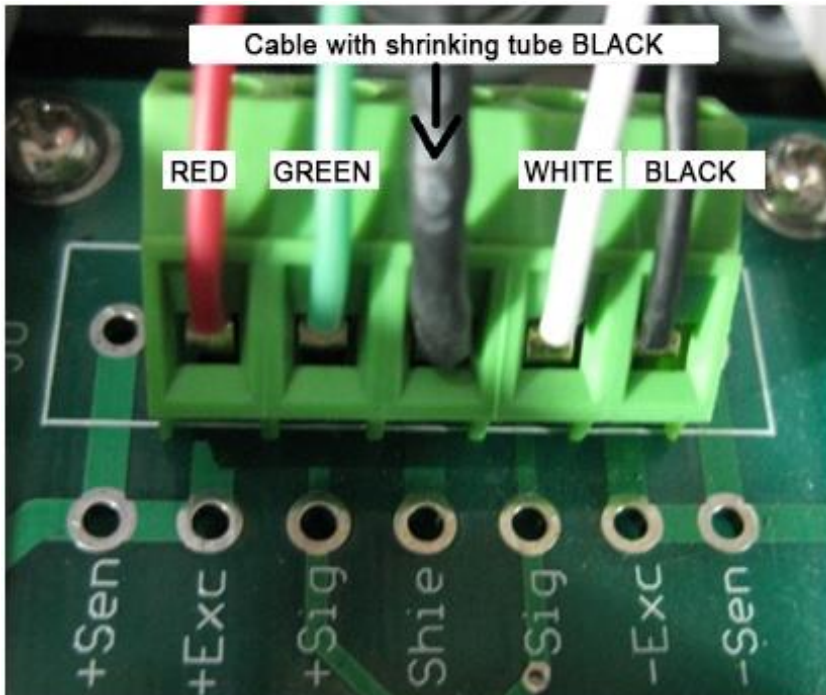

4.3.3 RS-232 interface

You can connect different external devices thanks to the RS-232 interface of the scales.

Caution: Pin assignment of the connection cable and the interface parameters must be noticed.

connection:

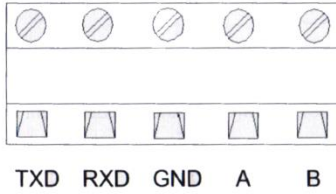

Pin definitions:

Pins	Definitions	Function
RS232	TXD	Sending data
	RXD	Receiving data
	GND	Ground
RS485	A	RS485 output "A"port
	B	RS485 output "B"port

RS232 : DB9 Pin or 3 Pin

DB9 definition

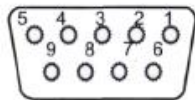

Pin function and definition as follows:

DB9 joint	Definition	Function
2	TXD	Sending data
3	RXD	Receiving data
5	GND	Ground interface

Note: if RS485, The connection pin is 2 and 5 pin.

3 Pin definition

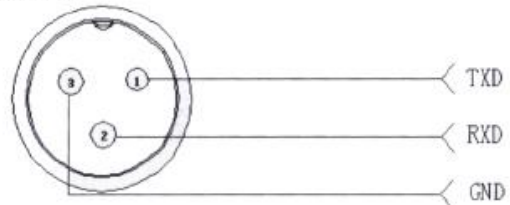

The display possesses a bidirectional RS-232 interface. This means that it is possible to control the interface with the help of query commands. Therefore, there is the possibility to send a query from your computer to the software of the scales and process the queried data afterwards.

Query	Definition	Function
T	Taring / TARE	Tares weight
Z	Zeroing / ZERO	Zeroes weight
P	Printing / Print	Query weight
G	Switch between Gross / Net	Change between weight indication Gross / Net
R	Repeat query	Repeat the last query
C	Kg / lb	Change between the weight units kg / lb

R command receive data format

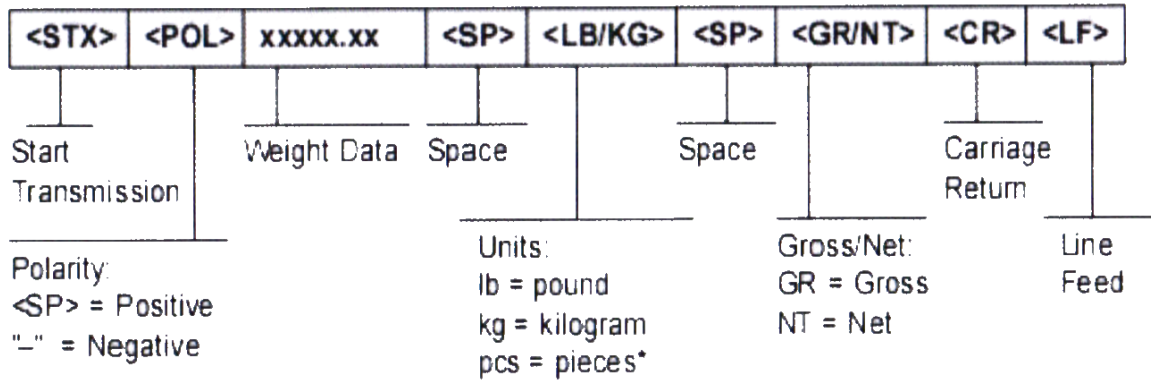

Depending on the transfer format, the data look as described in the following:

Tare mode:

Date: XX.XX. XX
 Time: XX: XX: XX
 NET XX.X kg
 TARE XX.X kg
 GROSS XXX.X kg

Gross mode:

Date: XX.XX. XX
 Time: XX: XX: XX
 GROSS XXX.X kg

4.3.4 Sending format

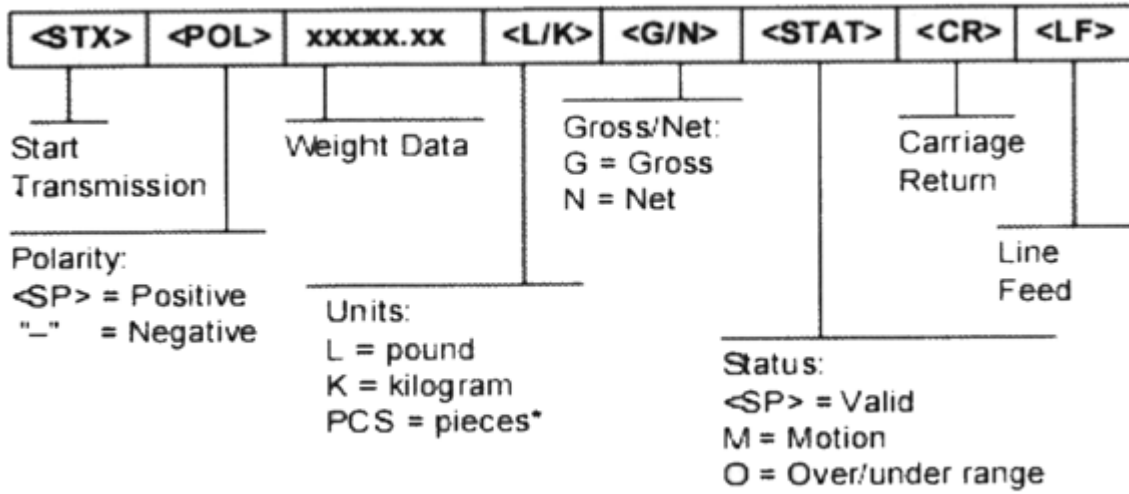

Output continuous format																	
S	S	S	S	X	X	X	X	X	X	X	X	X	X	X	X	C	C
T	W	W	W												R	K	
X	A	B	C												S	S	
1	2		3				4				5	6					

State A				
Bits0,1,2				
0	1	2	Decimal point position	
0	1	0	XXXXXXXX	
1	1	0	XXXXX. X	
0	0	1	XXXX. XX	
1	0	1	XXX. XXX	
Bits3,4			Division	
0		1	X1	
1		0	X2	

State B	
BitsS	function
Bits0	gross=0, net=1
Bits1	Symbol: positive =0,negative =1
Bits2	Overload(or under zero)=1
Bits3	dynamic=1
Bits4	unit: lb=0, kg=1
Bits5	Constant 1
Bits6	Constant 0

State C			
Bit2	Bit1	Bit0	unit
0	0	0	Kg or lb
0	0	1	g
0	1	0	t
Bit 3			printing=1
Bit 4			Extend display=1
Bit 5			Constant 1
Bit 6			Constant 0

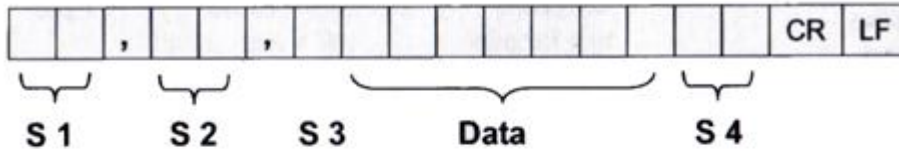

- S1: weight status, ST= standstill, US= not standstill, OL= overload
- S2: weight mode, GS=gross mode, NT=net mode
- S3: weight of positive and negative, "+" or "-"
- S4: "kg" or "lb"
- Data: weight value, including decimal point
- CR: carriage return
- LF: line feed

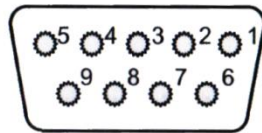

DB9 pin	definition	port
1 pin	1 st output signal pin	Out1
6 pin	1 st output signal pin	Out1
2 pin	2 nd output signal pin	Out2
7 pin	2 nd output signal pin	Out2
3 pin	3 rd output signal pin	Out3
8 pin	3 rd output signal pin	Out3
4 pin	4 th output signal pin	Out4
9 pin	4 th output signal pin	Out4

Inner connection pin definitions

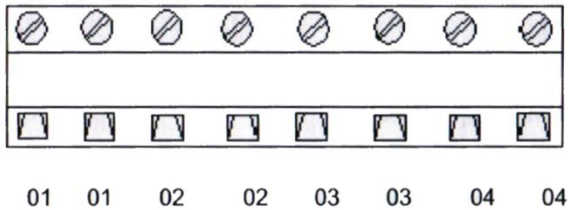

4.4 Operation

4.4.1 Turn ON/OFF



1. **Turn ON:** Press  and hold it, until the scales are turned on. The display does perform a self test then and switches to the normal measurement mode. As soon as the sign indicates stable operation (see picture), you can start the weighing.

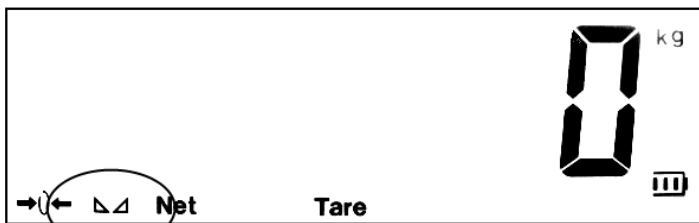

In case that the scales do not react, check the power supply of the display. If the sign for stable operation does not appear, check the subsurface and align the scales.



2. **Turn off:** Press  and hold it until the scales turn off.

4.4.2 Zeroing

When you turn on the scales, the initial weight should be zero to achieve correct measurement results. The scales filter possible loads automatically, to ensure, that 0 kg is displayed in the starting process.



If, nevertheless, zero should not be displayed on the display, use  the “ZERO” button to zero the display. The zeroed value is not considered in the gross / net evaluation.

If the zeroing function is activated, there is ->0<- on the bottom left side of the display.



If you want to display the present weight after starting the scales (useful for container weighing), you need to change some items in the menu screen. Refer to the menu mode C07 / C08 / C09 as well as C05 to determine the internal zero position.

4.4.3 Taring “TARE”

This function makes it possible to determine Gross / Net weight. Due to this function, it is possible to exclude the weight of a pallet for example.



Put an empty pallet on the scales and press the  “TARE” button. If the tare weight is registered, the “Tare” appears on the display.

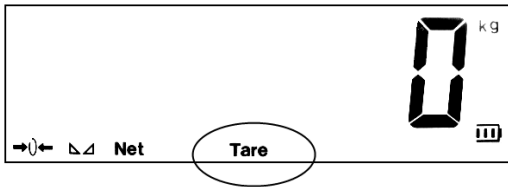

4.4.4 GROSS / NET



If the "TARE" function is used, the weight on the display can be displayed as net or gross weight (weight with or without pallet).

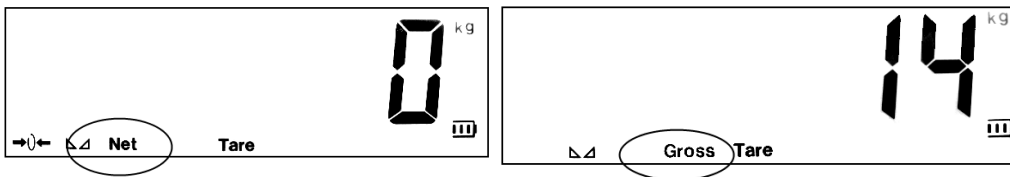

Press the "GROSS" button to display the particular weight on the display. Furthermore, there will be an indication, if the weight is displayed as gross or net weight. The value of the gross weight will only appear for a short period and switch back automatically.







4.4.5 Summing "TOTAL"

The function makes it possible to sum up several weights. This function is useful, if you wish to monitor the loading of vehicles, for example. Press the  "TOTAL" button, if the scales have determined the weight. The display shows "n 001" after you have pressed the  "TOTAL" button.

This indicates, that a weighing is registered in the summing memory. The value increases every time you press the  "TOTAL" button. If this function is activated, on the bottom left side of the display, the indication ->Total<- will appear.







In order to check the total sum, press the  "PRINT" button and the  "TOTAL" button simultaneously. The amount of saved values (for example "n 008" = 8 values) and the total sum will very briefly appear on the display.



To exit this display and return to the normal weighing mode, you need to press the  "TOTAL" button until ->CLr n<- appears on the display. It is possible to delete the memory of summations by changing the ->CLr n<- (delete no) to ->CLr Y<- (delete yes) due to the  "ZERO" button. To confirm the entry, you need to press the  "PRINT" button. Exit the function over ->CLr n<- (delete no) to continue with the summing function.

4.4.6 Piece counting function “COUNT”

This function makes it possible to count pieces of the same weight. Therefore, it is necessary to store the particular weight of a piece, which is then divided by the total weight. The storage of the piece weight happens due to reference weighing. This makes it necessary to place some of the pieces (you want to weigh) on the scales and to confirm the amount of placed pieces, in advance.

Press  the “COUNT” button on the display of the scales. The display shows ->PCS 0<- now. By pressing the  “ZERO” button the amount of reference pieces can be changed. 5 / 10 / 20 / 50 / 100 / 200 and 500 can be selected. (the higher the amount of reference pieces, the better is the average for the piece counting and the subsequent piece counting process itself). Now, the amount of previously determined reference pieces needs to be placed on the scales. After you have confirmed that with the  “PRINT” button, the quantities as well as the piece counting unit ->PCS<- will appear on the display.



Pressing the  “COUNT” button the display will switch back to the normal weighing mode and the unit to ->kg<- . With the help of this button, you can now switch between the two mode whenever you want. The piece weight will be deleted, when you turn off the scales.

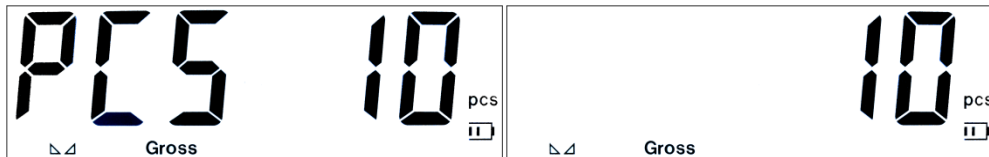

If a new piece weight shall be determined, press the  “COUNT” button and the  “PRINT” button simultaneously, to get back the position where you can select the amount of reference pieces 5 / 10 / 20 / 50 / 100 / 200 and 500.



4.5 Menu

The scales offer another variety of possible settings and functions. This can be set with the specific settings in the menu. For example, container weighing, animal weighing, weight monitoring, interface communication etc. can be set here. However, keep in mind that even basic settings which are incorrectly handled (for example wrong adjustment of the scales) can lead to incorrect measurements. The variety of settings is connected to the universal application of the display.

To reach the internal menu, press the  “HOLD” button and the  “PRINT” button simultaneously. ->C 01<- will appear in the display.









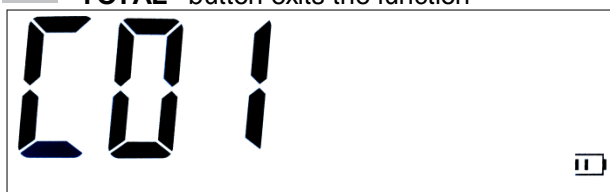











 “ZERO” and  “TARE” button change the number.

 “COUNT” and  “GROSS” button change the position



























 “Print” button confirms the entry or enters the function



















 “TOTAL” button exits the function













Menu item	Possible settings	Procedure
C 01 Select measurement unit	No possibility, because "kg" is fixed C1 1=kg C2 2=lb	
C 02 Setting decimal digit	C2 0=none C2 1=one digit C2 2=two digits C2 3=three digits C2 4=four digits	 Enter function "C 02"  ↑  ↓ Select setting  Confirm
C 03 Setting resolution steps	C3 1 = Steps of one C3 2 = Steps of two C3 5 = Steps of five C3 10 = Steps of ten C3 20 = Steps of twenty C3 50 = Steps of fifty	 Enter function "C 03" Select the function with  ↑ and  ↓  Confirm
C 04 Setting measurement range [MAX]	The number of maximum load can be entered here. An example is 1500.0. (the measurement unit of the value is kg)	 Enter function "C 04" Setting of the value with  ↑ and  ↓ as well as with  ← and  →  Confirm <hr/>  return to normal weighing mode
C 05 Setting zero position	If the display shows the error message „nnnnnn“, the zero position is displaced and should be readjusted as described on the right. The zero position tells the scales, when they have to display 0 kg. This option is useful, if there was a change of the scales as for example its installation C 5 0 = no setting C 5 1 = setting of the zero position for the following calibration C 5 2 = setting of the zero position without the need to recalibrate the scales	 Enter function "C 05" Depending on the zero position, the platform needs to be empty or put on after installation.  Confirm pressing (The display shows CAL 9 and the countdown starts) Select the function with  ↑ and  ↓ 0 / 1 / 2  Confirm with "0", "0" is displayed again.











		<p>The display will show menu item "C 06" then.</p>
<p>C 06 Adjustment of the scales</p>	<p>If the scales show deviating weights, the scales can be readjusted. Before you do that, you should however carry out zero position adjustment „C 05“.</p> <p>C 6 0 = no adjustment</p> <p>C 6 1 = one-point adjustment (adjustment with only one weight)</p> <p>C 6 2 = multipoint adjustment (adjustment with up to 7 weights)</p> <p>C 6 3 = voltage adjustment (Adjustment with the help of voltages mV/V)</p> <p>Before an adjustment is carried out, you should check, if the scales are horizontally placed on a solid surface and if weighing cells as well as platform are empty.</p> <p>After that, you should prepare the weights for the adjustment, where 2/3 of the maximum load is recommended as adjustment weight.</p> <p>Multipoint adjustment is the best possibility to reach the highest possible accuracy of the scales.</p>	<p> back to the normal weighing mode</p> <p> Enter function "C 06"</p> <p>Select the function with ↑ and ↓ C6 0 / 1 / 2 or 3</p> <p> Confirm</p> <hr/> <p>"C6 1" one point adjustment On the display, „SPAn“ and then „000150“ will appear. Here, you need to adjust the adjustment weight, which is used. Then, you need to put the weight on the scales and press </p> <p>The display shows CAL 9 then and the countdown begins. "CAL End" will appear in the display and you need to press to confirm.</p> <hr/> <p>"C6 2" Multipoint adjustment „SPAn“ will shortly appear on the display. After that, "LnE 2" appears on the display. You need to adjust the amount weights for morepoint adjustment.</p> <p>Setting of the amount with ↑ and ↓</p> <p>Press to confirm.</p> <p>Display shows "bdno 01" and "001000" where you need to set the weight of the first adjustment point. After that, you need to put the weight on the scales and press . (The display shows CAL 9 and the countdown starts.</p> <hr/> <p>"C6 3" Voltage adjustment mV/V</p>

		<p>“SPAn” will shortly appear on the display. After that, “046123” appears on the display. You can enter the calculated voltage ratio.</p> <p>The voltage ratio differs in the dependence of the cell and you need experience to determine it. After the</p>  <p>entry, you confirm with .</p> <p>“CAL End” will appear on the display and</p>  <p>you need to confirm with .</p> <hr/>  <p>back to the normal weighing mode</p>
<p>C 07 Factory settings</p>	<p>The scales can be reset to factory settings here.</p> <p>C 7 ... 0 = leave menu</p> <p>C 7 1 = reset settings</p>	 <p>Enter function “C 07”</p>   <p>Select the function with  and  ↓ C7 0 or 1</p>  <p>Confirm</p> <hr/>  <p>return to normal weighing mode</p>
<p>C 08 Warning signal (Beep)</p>	<p>The beep can be turned on or off here.</p> <p>C 8 0 = beep off</p> <p>C 8 1 = beep on</p>	 <p>Enter function “C 08”</p>   <p>Select the function with  and  ↓ C8 0 or 1</p>  <p>Confirm</p> <hr/>  <p>return to normal weighing mode</p>
<p>C 09 Automatic turn-off</p>	<p>You can set automatic turn-off of the scales here. If the scales are not used in the adjusted time period, they switch off automatically to spare battery.</p> <p>C 9 0 = deactivate auto turn-off</p> <p>C 9 10 = auto turn-off after 10 minutes</p> <p>C 9 30 = auto turn-off after 30 minutes</p> <p>C 9 60 = auto turn-off after 60 minutes</p>	 <p>Enter function “C 09”</p>   <p>Select the function with  and  ↓ C9 0 / 10 / 30 or 60</p>  <p>Confirm</p> <hr/>  <p>return to normal weighing mode</p>
<p>C 10 Display illumination</p>	<p>You can set the time of display illumination here:</p>	 <p>Enter function “C 10”</p>

















	<p>C 10 0 = deactivate display illumination</p> <p>C 10 1 = 10 minutes</p> <p>C 10 2 = switch on permanently</p>	<p>Select the function with  ↑ and  ↓ C10 0 / 1 or 2</p> <p> Confirm</p> <hr/> <p> return to normal weighing mode</p>
<p>C 11 Hold</p>	<p>You can set the value when the weight shall be hold on the display here.</p> <p>C 11 0 = deactivate HOLD</p> <p>C 11 1 = PEAK / MAX value (The highest measured value is displayed)</p> <p>C 11 2 = with button press (the value is hold, if  is pressed)</p> <p>C 11 3 = automatically (if the weight is stable, the value is automatically hold on display, even when the load i stake from the scales)</p> <p>C 11 4 = animal counting function (an average value from more measurements is displayed, to filter the movements of animals)</p>	<p> Enter function “C 11”</p> <p>Select the function with  ↑ and  ↓ C 11 0 / 1 / 2 / 3 or 4</p> <p> Confirm</p> <hr/> <p> return to normal weighing mode</p>
<p>C 12 Animal counting fuction</p>	<p>You can set the filter time for animal counting (C11 – 4) here.</p> <p>C 12 3 = average of all measurements of the last 3 seconds</p> <p>C 12 5 = average of all measurements of the last 5 seconds</p>	<p> Enter function “C 12”</p> <p>Select the function with  ↑ and  ↓ C 12 3 or 5</p> <p> Confirm</p> <hr/> <p> return to normal weighing mode</p>
<p>C 13 Set upper alarm limit (HI / MAX)</p>	<p>Set the upper alarm limit to classify weight determination MIN / OK / MAX (Lo / OK / Hi)</p> <p>When exceeding the adjusted values, the “Hi” appears on the display.</p> <p>For optional switch outputs, this is also the upper switching limit.</p> <p>If the weight is in the „Lo“ or „Hi“ range, a warning tone arises, if the function “C 08”</p>	<p> Enter function “C 13”</p> <p>Display shows e.g. „000000“. You should enter the upper weight limit (Hi) here.</p> <p> Confirm</p> <hr/> <p> return to normal weighing mode</p>

	<p>is activated.</p> <p>Above the “Lo” and beneath the “Hi” limit, the display shows “OK” and the scales do not produce a warning tone.</p>	
<p>C 14 Set lower alarm limit (Lo / MIN)</p>	<p>Set the lower alarm limit to classify weight determination MIN / OK / MAX (Lo / OK / Hi)</p> <p>When falling below the adjusted values, “Lo” appears on the display.</p> <p>For optional switch outputs, this is also the lower switching limit.</p> <p>If the weight is in the „Lo“ or „Hi“ range, a warning tone arises, if the function “C 08” is activated.</p> <p>Above the “Lo” and beneath the “Hi” limit, the display shows “OK” and the scales do not produce a warning tone.</p>	<p> Enter function “C 14”</p> <p>Display shows e.g. “000000“. You should enter the lower weight limit (Lo) here.</p> <p> Confirm</p> <hr/> <p> return to normal weighing mode</p>
<p>C 15 AD converter display</p>	<p>This value stands for the analog value coming from the cell. It is used by the AD converter to perform the conversion to a weight.</p> <p>With the help of this value, you can check, in which measurement range the cells of the scales work.</p>	<p> Enter function “C 15”</p> <p><i>There cannot be changed anything within this function. It is only made for information and evaluation purposes of the scales condition.</i></p> <p> Confirm</p>
<p>C 16 Date setting</p>	<p>The scales possess an internally installed clock. This makes it possible to print time and date incl. weight with connected printer.</p>	<p> Enter function “C 16”</p> <p>Display shows e.g. “14.01.03“.</p> <p>The format you need to set is YEAR / MONTH / DAY</p> <p> Confirm</p>
<p>C 17 Time setting</p>	<p>The scales possess an internally installed clock. This makes it possible to print time and date incl. weight with connected printer.</p>	<p> Enter function “C 17”</p> <p>Display shows e.g. „19.07.22“.</p> <p>The format you need to set is HOUR / MINUTE / SECOND</p> <p> Confirm</p>
<p>C 18 Setting data transfer</p>	<p>Here, you can set the time when the weighing data shall be transferred via the</p>	<p> Enter function “C 18”</p>













	<p>interface of the scales.</p> <p>C 18 0 = interface deactivated</p> <p>C 18 1 = continuous data transfer in large display format</p> <div style="border: 1px solid red; padding: 5px; display: inline-block;"> </div> <p>C 18 2 = Data transfer at touch of a button in printer format</p> <div style="border: 1px solid red; padding: 5px; display: inline-block;"> <p>Date: 14.01.03 Time: 12:47:36 Gross 125kg</p> </div> <p>C 18 3 = data query due to computer Refer to the interface description for the commands</p> <p>C 18 4 = continuous data transfer</p> <div style="border: 1px solid red; padding: 5px; display: inline-block;"> <p>ST,GS,+ 112kg ST,GS,+ 112kg ST,GS,+ 112kg ST,GS,+ 112kg</p> </div>	<div style="text-align: right;"> </div> <p>Select the function with ↓ C 18 0 / 1 / 2 / 3 or 4</p> <div style="border: 1px solid black; padding: 5px; display: inline-block;"> </div> Confirm <hr/> <div style="border: 1px solid black; padding: 5px; display: inline-block;"> </div> <p>return to normal weighing mode</p> <p>In the course of the connection of scales and computer the pin assignment with the interface needs to be according to description in XXX, to make the data transfer possible.</p>
<p>C 19 Setting baud rate</p>	<p>You can set the baud rate of the scales here. It needs to be adjusted to the interface of the receiver to display the weighing data correctly.</p> <p>C 19 0 = 1200 baud rate</p> <p>C 19 1 = 2400 baud rate</p> <p>C 19 2 = 4800 baud rate</p> <p>C 19 3 = 9600 baud rate</p>	<div style="border: 1px solid black; padding: 5px; display: inline-block;"> </div> Enter function "C 19" <div style="text-align: right; margin-top: 10px;"> </div> <p>Select the function with ↓ C 19 0 / 1 / 2 or 3</p> <div style="border: 1px solid black; padding: 5px; display: inline-block;"> </div> Confirm <hr/> <div style="border: 1px solid black; padding: 5px; display: inline-block;"> </div> <p>return to normal weighing mode</p>
<p>C 20 ZERO range</p>	<p>You can set the ZERO range with the help of here.</p> <p>ZERO is not the same as TARA, because ZERO is not considered in the Gross / Net calculation (in contrast to TARA).</p> <p>The setting are made in % to MAX</p> <p>C 20 00 = „ZERO“ deactivated</p> <p>C 20 01 = 1% can be zeroed</p> <p>C 20 02 = up to 2%</p>	<div style="border: 1px solid black; padding: 5px; display: inline-block;"> </div> Enter function "C 20" <div style="text-align: right; margin-top: 10px;"> </div> <p>Select the function with ↓</p> <div style="border: 1px solid black; padding: 5px; display: inline-block;"> </div> Confirm <hr/> <div style="border: 1px solid black; padding: 5px; display: inline-block;"> </div> <p>return to normal weighing mode</p>

	<p>C 20 04 = up to 4%</p> <p>C 20 10 = up to 10%</p> <p>C 20 20 = up to 20%</p> <p>C 20 100 = up to 100%</p>	
<p>C 21 Setting Start / Auto ZERO function</p>	<p>At the start of the scales, the weight which is possibly zeroed on the scales. Here, you can set the zero position and deactivate auto zeroing.</p> <p>C 21 00 = no AUTO zeroing</p> <p>C 21 01 = up to 1% is zeroed</p> <p>C 21 02 = up to 2%</p> <p>C 21 05 = up to 5%</p> <p>C 21 10 = up to 10%</p> <p>C 21 20 = up to 20%</p> <p>C 21 100 = up to 100%</p> <p>Deactivation of the zeroing is useful with for example container weighing, should however only be performed in combination with a zero position "C 05" (empty weight) to weigh the container ingredients.</p>	<p> Enter function "C 21"</p> <p>Select the function with   ↑ and ↓</p> <p> Confirm</p> <hr/> <p> return to normal weighing mode</p>
<p>C 22 Adjustable automatic zeroing</p>	<p>Since the displayed weight is based on the conversion of a signal, which comes from a cell, there cannot be signal fluctuations under any circumstances. With the help of this function, the range of the fluctuations compensating the display, can be set.</p> <p>These lead to a stable weight indication on the display.</p> <p>d = resolution steps</p> <p>C 22 0,5 = compensation up to ±0,5d</p> <p>C 22 1,0 = compensation up to ±1,0d</p> <p>C 22 2,0 = compensation up to ±2,0d</p> <p>C 22 3,0 = compensation up to ±3,0d</p> <p>C 22 4,0 = compensation up to ±4,0d</p> <p>C 22 5,0 = compensation up to ±5,0d</p>	<p> Enter function "C 22"</p> <p>Select the function with   ↑ and ↓</p> <p> Confirm</p> <hr/> <p> return to normal weighing mode</p>

	<p>Cannot be higher than the „C 20“ zeroing</p>	
<p>C 23 Setting automatic zeroing time</p>	<p>You can set the reaction time for the automatic</p> <p>Hier kann die Reaktionszeit der automatischen Nullnachführung eingestellt werden.</p> <p>C 23 0 = no</p> <p>C 23 1 = 1 second</p> <p>C 23 2 = 2 seconds</p> <p>C 23 3 = 3 seconds</p>	<p> Enter function “C 23”</p> <p>Select the function with ↑ and ↓</p> <p> Confirm</p> <hr/> <p> return to normal weighing mode</p>
<p>C 24 Setting overload tolerance “uuuuuu”</p>	<p>You can set how many resolution steps over the maximum load are necessary to display the error message in form of “uuuuuu”.</p> <p>The display of this error message can be used to protect the user or to meet certain requirements.</p>	<p> Enter function “C 24”</p> <p>Display shows „C 24 09“ = 09 d are 9 resolution steps. You can set up to 99 d here.</p> <p>Select the function with ↑ and ↓</p> <p> Confirm</p> <hr/> <p> return to normal weighing mode</p>
<p>C 25 Setting underload tolerance “nnnnnn”</p>	<p>You can set how many percent of the maximum load are displayed until the error message “nnnnnn” appears on the display.</p> <p>C25 0 = - 20d (resolution steps)</p> <p>C25 10 = 10% of the maximum load</p> <p>C25 20 = 20% of the maximum load</p> <p>C25 50 = 50% of the maximum load</p> <p>C25 100 = 100% of the maximum load</p>	<p> Enter function “C 25”</p> <p>Select the function with ↑ and ↓</p> <p> Confirm</p> <hr/> <p> return to normal weighing mode</p>
<p>C 26 Setting stabilization speed</p>	<p>You can set the reaction time of the stabilization indicator „ “ here. This means that you adjust if the indicator shall appear fast, medium or slow on the display.</p> <p>C26 0 = fast</p> <p>C26 1 = medium</p>	<p> Enter function “C 26”</p> <p>Select the function with ↑ and ↓</p> <p> Confirm</p>

	<p>C26 3 = slow</p> <p>Adjustment of the indication speed can be useful when it comes to different weighing goods and the context with the automatic data replay with stable values.</p>	 return to normal weighing mode
<p>C 27</p> <p>Setting stabilization range</p>	<p>The reaction steps of the stabilization indicator „ΔΔ “ can be set:</p> <p>C27 1 = 1d (1 reaction step)</p> <p>C27 2 = 2d (2 reaction steps)</p> <p>C27 5 = 5d (5 reaction steps)</p> <p>C27 10 = 10d (10 reaction steps)</p>	 Enter function “C 27” Select the function with  ↑ and  ↓  Confirm <hr/>  return to normal weighing mode
<p>C 28</p> <p>Setting dynamic filter</p>	<p>Here, the dynamic filter can be set. It is a filter which screens the movements on the scales before the value appears on the display.</p> <p>C28 1 = 1 filter strength</p> <p>C28 2 = 2 filter strengths</p> <p>C28 3 = 3 filter strengths</p> <p>C28 4 = 4 filter strengths</p> <p>C28 5 = 5 filter strengths</p> <p>C28 6 = 6 filter strengths</p> <p>The higher the filter strength, the slower is the reaction of the scales to weight changes / fluctuations.</p>	 Enter function “C 28” Select the function with  ↑ and  ↓  Confirm <hr/>  return to normal weighing mode
<p>C 29</p> <p>Setting noise filter</p>	<p>You can set a filter, to suppress signal noise here.</p> <p>C29 1 = 1 filter strength</p> <p>C29 2 = 2 filter strengths</p> <p>C29 3 = 3 filter strengths</p>	 Enter function “C 29” Select the function with  ↑ and  ↓  Confirm <hr/>  return to normal weighing mode
<p>C 31 ** (OPTION)</p> <p>Setting analogue output signal</p>	<p>You can set an analog signal, which is better suited for your instruments here.</p> <p>C31 0 = 0 – 5 V (20mA)</p> <p>C31 1 = 4 – 20 mA</p>	 Enter function “C 31”

		<p>Select the function with ↑ and ↓</p> <p> Confirm</p> <hr/> <p> return to normal weighing mode</p>
<p>C 32 ** (OPTION) Setting parameterization of the analogue interfaces</p>	<p>C32 oUt 4 =</p> <p>C32 oUt 5 =</p> <p>C32 oUt 6 =</p> <p>C32 oUt .. =</p> <p>C32 oUt .. =</p> <p>C32 oUt 20 =</p>	<p> Enter function “C 32”</p> <p>Select the function with ↑ and ↓</p> <p> Confirm</p> <hr/> <p> return to normal weighing mode</p>
<p>C 33 ** (OPTION) Setting relay output</p>	<p>C33 0 = Relay output deactivated</p> <p>C33 1 = Relay output Mode 1</p> <p>C33 2 = Relay output Mode 2</p> <p>C33 3 = without function</p>	<p> Enter function “C 33”</p> <p>Select the function with ↑ and ↓</p> <p> Confirm</p> <hr/> <p> return to normal weighing mode</p>
<p>C 34 ** (OPTION) Setting of the communication address (without function)</p>	<p>C 34 .. = 0-99</p>	<p> Enter function “C 34”</p> <p>Select the function with ↑ and ↓</p> <p> Confirm</p> <hr/> <p> return to normal weighing mode</p>
<p>C 35 ** (OPTION) Setting wireless communication address (without function)</p>	<p>C 35 .. = 0-99</p>	<p> Enter function “C 35”</p> <p>Select the function with ↑ and ↓</p>

		 Confirm
		 return to normal weighing mode
C 36 Setting the gravity for adjustment	You can set the gravity here. It is a conversion factor for the correct determination of weight. Adjust the value to the gravity of the country you want to use the scales. $C\ 36 = 09,7936\ m/s^2$ The average in Germany is 9,8100 (keep that in mind when installing the scales)	 Enter function "C 36" Select the function with  ↑ and  ↓  Confirm
		 return to normal weighing mode
C 37 Setting the gravity of the installation side	$C\ 37 = 09,7936\ m/s^2$ The average in Germany is 9,8100	 Enter function "C 37" Select the function with  ↑ and  ↓  Confirm
		 return to normal weighing mode
C 38	13.06.28 PCoO21 PC-41A	 Enter function "C 38"
C 39		

5 Maintenance and Cleaning

5.1 Battery information

A high-quality battery is integrated in the device. Its complete capacity will only be achieved after the second or third charging process, where its charging time should be between 6 and 8 hours. If the battery is completely charged, its working time should be between 20 and 30 hours.

If the device shows **LOWBATT**, the battery needs to be recharged immediately, because a low battery can cause measurement mistakes.

5.2 Mains operation



Warning: In order to make sure, there are no measurement errors and resulting problems, load the battery, as soon as the indication tells you to. After charging the battery for 12 hours, it should be completely charged. After multiple applications, the battery capacity might decrease.

5.2.1 Cleaning

Clean the instrument with a wet lint-free cotton cloth and a gentle cleaner, if necessary. Do not use abrasives or solvents under any circumstances.

6 Disposal

For the disposal of batteries, the 2006/66/EC directive of the European Parliament applies. Due to the contained pollutants, batteries must not be disposed of as household waste. They must be given to collection points designed for that purpose.

In order to comply with the EU directive 2012/19/EU we take our devices back. We either re-use them or give them to a recycling company which disposes of the devices in line with law.

If you have any questions, please contact PCE Instruments.

7 Contact

If you have any questions about our range of products or measuring instruments please contact PCE Instruments.

7.1 PCE Instruments UK

By post:

PCE Instruments UK Ltd.
Units 12/13 Southpoint Business Park
Ensign Way, Southampton
Hampshire

United Kingdom, SO31 4RF

By phone:

02380 987 035

7.2 PCE Americas

By post:

PCE Americas Inc.
711 Commerce Way
Suite 8
Jupiter
33458 FL
USA

By phone:

561 320 9162

